

LACAVA

FLUTTI

built-in pressure balanced progressive mixer
w/3-way diverter

16PBP3.X.S, 16PBP3S.X.S

16PBP3.X.SF, 16PBP3S.X.SF

Specifications:

Installation:	built-in wall mount	
Exterior Dimensions:	W: 5 1/8" H: 7 1/4"	
Material:	solid brass construction with progressive ceramic cartridge and 3-way diverter cartridge	
Water use:	4.2 GPM (43.5 PSI)	
Finishes:	CR - polished chrome	PB - polished bronze
	PN - polished nickel	GM - gun metal
	NI - brushed nickel	51 - brushed brass
	BG - brushed gold	BB - brushed bronze
	44 - matte black	TN - titanium
	PS - polished brass	BK - black chrome
Fittings as selected:	#VPBP3 (non sharing) + #16PBP3.X.S-A (without flutes)	16PBP3.X.SF (non-sharing)
	#VPBP3 (non sharing) + #16PBP3.X.SF-A (with flutes)	16PBP3S.X.SF (sharing)
	#VPBP3S (sharing) + #16PBP3.X.S-A (without flutes)	
	#VPBP3S (sharing) + #16PBP3.X.SF-A (with flutes)	
Tile opening max size:	W: 4" H: 5 3/4"	



16PBP3.X.SF (non-sharing)
16PBP3S.X.SF (sharing)

16PBP3.X.S (non-sharing)
16PBP3S.X.S (sharing)

Features:

- unibody pressure balancing progressive valve with 3-way diverter and OFF function
- trim sold separately
#16PBP3.X.S-A (without flutes)
#16PBP3.X.SF-A (with flutes)
- cross handles and rectangular backplate
- non-sharing 3-way diverter valve with 360° rotating angle # VPBP3
- sharing 3-way diverter valve with 360° rotating angle # VPBP3S
- anti-scald protection & temperature regulation for flow rates as low as 1.75 GPM
- screwdriver service stops
- finished wall must be flush with mudguard as marked
- 1/2" Male NPT inlets & outlets, optional sweat connection
- 1" extension kit available



NON-SHARING

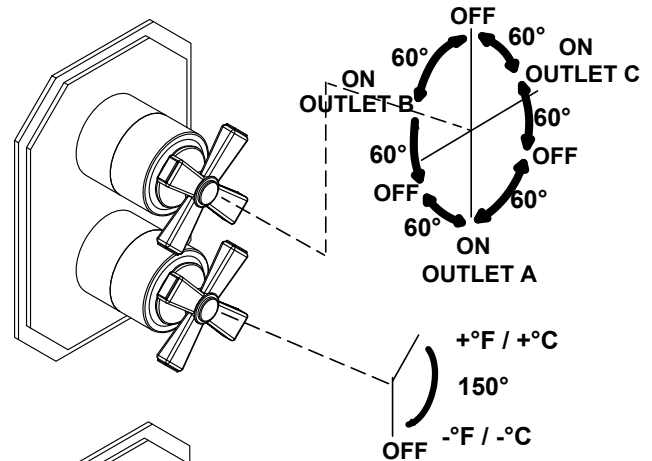

Codes + Standards:

- Meets and exceeds applicable national codes
 - ASME A112.18.1/CSA B125.1
 - ASSE 1016/ASME A112.1016/CSA B125.16
- CAL-Green compliant (non-sharing valves)

ADA compliant when installed to specific requirements of this regulation

Recommended Items:

- Replacement parts:
 - VPBP-C ceramic cartridge
 - VD3-C- diverter cartridge, non-sharing
 - VD3S-C- diverter cartridge, sharing
 - VPBP3-EX 1" extension kit

LACAVA reserves the right to revise any dimension or information on this sheet without notice. Dimensions are nominal and may vary within an industry accepted tolerance of 1/4". Drawings provided herein are meant to give the user an idea of the product and are not made to scale.

Revised: 1/16/26

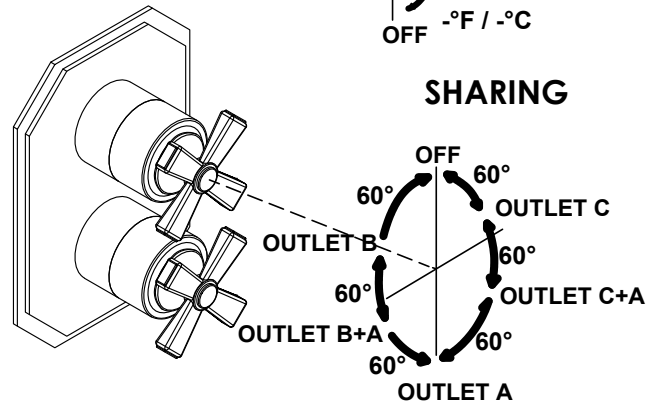

SHARING

